

Condensing units for air
handling applications
(pair)
Technical data book
ERQ-AV1



ERQ100A7V1B
ERQ125A7V1B
ERQ140A7V1B

Table of contents

ERQ-AV1

1	Features	4
	ERQ-AV1	4
2	Specifications	5
3	Electrical data	7
4	Options	8
5	Selection procedure	9
6	Combination table	10
7	Capacity tables	11
	Cooling Capacity Tables	11
	Heating Capacity Tables	17
	Capacity Correction Factor	23
8	Dimensional drawings	24
9	Centre of gravity	25
10	Piping diagrams	26
11	Wiring diagrams	27
	Wiring Diagrams - Single Phase	27
12	External connection diagrams	28
13	Sound data	29
	Sound Power Spectrum	29
	Sound Pressure Spectrum - Cooling	31
	Sound Pressure Spectrum - Heating	34
14	Installation	37
	Installation Method	37
15	Operation range	38

1 Features

1 - 1 ERQ-AV1

- › Benefit from the high efficiency and fast response to changing loads of ERQ condensing units
- › Inverter controlled outdoor unit
- › Predefined combinations with Daikin Modular air handling unit offer ready to use 'fresh air packages'
- › R-410A heat pump



2 Specifications

1 - 1 ERQ-AV1

Technical specifications					ERQ100AV1	ERQ125AV1	ERQ140AV1	
Cooling capacity	Nom.		kW		11.2 (1)	14.0 (1)	15.5 (1)	
Heating capacity	Nom.		kW		12.5 (2)	16.0 (2)	18.0 (2)	
Capacity range			HP		4	5	6	
Power input	Cooling	Nom.	kW		2.81 (1)	3.51 (1)	4.53 (1)	
	Heating	Nom.	kW		2.74 (2)	3.86 (2)	4.57 (2)	
EER					3.99 (1)		3.42 (1)	
COP					4.56 (2)	4.15 (2)	3.94 (2)	
PED	Category				Category I			
Dimensions	Unit	Height	mm		1,345			
		Width	mm		900			
		Depth	mm		320			
	Packed unit	Height	mm		1,524			
		Width	mm		980			
		Depth	mm		420			
Weight	Unit		kg		120			
	Packed unit		kg		130			
Packing	Material				Carton / EPS / Wood			
	Weight		kg		8			
Casing	Colour				Daikin White			
	Material				Painted galvanized steel plate			
Heat exchanger	Length		mm		857			
	Rows	Quantity			2			
	Fin pitch		mm		2			
	Passes	Quantity			10			
	Face area		m ²		1.131			
	Stages	Quantity			60			
	Tube type				ø8 Hi-XSS			
	Fin	Type			Non-symmetric waffle louvre			
		Treatment			Corrosion resistant			
	Fan	Type				Propeller fan		
		Discharge direction				Horizontal		
Quantity					2			
Air flow rate		Cooling	Nom.	m ³ /min		106		
Fan motor		Heating	Nom.	m ³ /min	102		105	
	Quantity				2			
	Model				Brushless DC motor			
	Output		W		70.00			
Fan motor 2	Drive				Direct drive			
	Speed	Cooling	Nom.	rpm		850		
		Heating	Nom.	rpm	820		840	
	Speed	Cooling	Nom.	rpm		815		
Compressor		Heating	Nom.	rpm	785		805	
	Quantity				1			
	Model				JT100G-VDL			
	Type				Hermetically sealed scroll compressor			
Speed			rpm		6,480			
Output			W	2,500	3,000	3,500		
Starting method					Direct on line			
Crankcase heater			W		33			
Operation range	Cooling	Min.	°CDB		-5			
		Max.	°CDB		46			
	Heating	Min.	°CWB		-20			
		Max.	°CWB		15.5			
	On coil temperature	Heating	Min.	°CDB		10		
		Cooling	Max.	°CDB		35		
Sound power level	Cooling	Nom.	dB(A)	66	67	69		
Sound pressure level	Cooling	Nom.	dB(A)	50	51	53		
	Heating	Nom.	dB(A)	52	53	55		
Refrigerant	Type				R-410A			
	Charge		kg		4.0			
	Charge		TCO2Eq		8.4			
	GWP				2,087.5			
	Control				Expansion valve (electronic type)			
	Circuits	Quantity			1			
Refrigerant oil	Type				Daphne FVC68D			
	Charged volume		l		1.5			
Defrost control					Sensor for outdoor heat exchanger temperature			
Defrost method					Reversed cycle			

4 Options

4 - 1 Options

ERQ-AV1

N°	Item	ERQ100	ERQ125	ERQ140
1	Cool/heat selector		KRC19-26A6	
2	Fixing box		KJB111A	
3	Central drain plug		KKPJ5F180	

Note: all options are kits

4TW32001-4

4

5 Selection procedure

5 - 1 Selection Procedure

ERQ-AV1

Integrated heating capacity coefficient

The heating capacity tables do not take account of the reduction in capacity, when frost has accumulated or while the defrosting operation is in progress. The capacity values, which take these factors into account, in other words, the integrated heating capacity values, can be calculated as follows

Formula:
 Integrated heating capacity = A
 Value given in table of capacity characteristics = B
 Integrating correction factor for frost accumulation (kW) = C
 $A = B \times C$

Correction factor for finding integrated heating capacity

Inlet port temperature of heat exchanger (°C/RH 85%)	-7	-5	-3	0	3	5	7
Integrating correction factor for frost accumulation	0,88	0,86	0,8	0,75	0,76	0,82	1,0

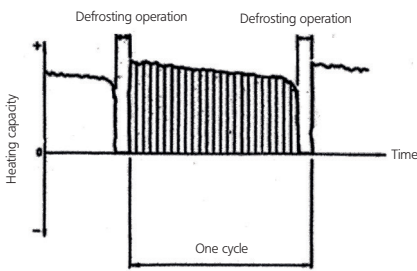

Note:
 1. The figure shows that the integrated heating capacity expresses the integrated capacity for a single cycle (from defrost operation to defrost operation) in terms of time.

Please note that, when there is an accumulation of snow against the outside surface of the outdoor unit heat exchanger, there will always be a temporary reduction in capacity, although this will of course vary in degree in accordance with a number of other factors, such as the outdoor temperature (°CDB), relative humidity (RH) and the amount of frosting which occurs.

3TW30402-1

6 Combination table

6 - 1 Combination Table

6
ERQ-AV1
Combination table

Outdoor unit		Control box			Expansion valve kit					
		EKEQDCBV3	EKEQFCBV3	EKEXV63	EKEXV80	EKEXV100	EKEXV125	EKEXV140	EKEXV200	EKEXV250
1 ph	ERQ100	P	P	P	P	P	P	-	-	-
	ERQ125	P	P	P	P	P	P	P	-	-
	ERQ140	P	P	-	P	P	P	P	-	-
3 ph	ERQ125	P	P	P	P	P	P	P	-	-
	ERQ200	P	P	-	-	P	P	P	P	P
	ERQ250	P	P	-	-	-	P	P	P	P

Heat pump

P: Pair: Combination depending on AHU heat exchanger volume and capacity

EKEXV Class	Allowed heat exchanger volume (dm ³)		Allowed heat exchanger capacity (kW)	
	Minimum	Maximum	Minimum	Maximum
63	1.66	2.08	6.3	7.8
80	2.09	2.64	7.9	9.9
100	2.65	3.3	10	12.3
125	3.31	4.12	12.4	15.4
140	4.13	4.62	15.5	17.6
200	4.63	6.6	17.7	24.6
250	6.61	8.25	24.7	30.8

 Saturated suction temperature (SST) = 6°C, Superheat (SH) = 5K
 Air temperature = 27°CDB/19°CWB

If conflicting result occurs, capacity selection has priority over volume.

3TW32009-1

7 Capacity tables

7 - 1 Cooling Capacity Tables

ERQ100AV1

Cooling

TC: Total capacity, kW; PI: Power Input, kW (Comp. + Outdoor fan motor)

Combination % kW (Capacity index)	Outdoor air temp. (°CDB)	Indoor air temp. °CWB													
		14.0 °CWB		16.0 °CWB		18.0 °CWB		19.0 °CWB		20.0 °CWB		22.0 °CWB		24.0 °CWB	
		20.0 °CDB		23.0 °CDB		26.0 °CDB		27.0 °CDB		28.0 °CDB		30.0 °CDB		32.0 °CDB	
		TC	PI	TC	PI	TC	PI	TC	PI	TC	PI	TC	PI	TC	PI
70% 7.84 kW (70.0)	10	5.29	0.68	6.31	0.80	7.33	0.94	7.84	1.01	8.35	1.08	9.37	1.23	10.4	1.38
	12	5.29	0.69	6.31	0.82	7.33	0.95	7.84	1.02	8.35	1.10	9.37	1.25	10.4	1.40
	14	5.29	0.70	6.31	0.83	7.33	0.97	7.84	1.04	8.35	1.12	9.37	1.27	10.4	1.43
	16	5.29	0.71	6.31	0.84	7.33	0.99	7.84	1.06	8.35	1.14	9.37	1.30	10.4	1.46
	18	5.29	0.72	6.31	0.86	7.33	1.01	7.84	1.08	8.35	1.16	9.37	1.32	10.4	1.49
	20	5.29	0.73	6.31	0.87	7.33	1.02	7.84	1.10	8.35	1.18	9.37	1.35	10.4	1.53
	21	5.29	0.74	6.31	0.88	7.33	1.03	7.84	1.11	8.35	1.19	9.37	1.37	10.4	1.58
	23	5.29	0.75	6.31	0.90	7.33	1.06	7.84	1.15	8.35	1.25	9.37	1.47	10.4	1.70
	25	5.29	0.77	6.31	0.93	7.33	1.13	7.84	1.23	8.35	1.34	9.37	1.57	10.4	1.81
	27	5.29	0.81	6.31	0.99	7.33	1.20	7.84	1.31	8.35	1.43	9.37	1.67	10.4	1.94
	29	5.29	0.86	6.31	1.06	7.33	1.28	7.84	1.40	8.35	1.52	9.37	1.78	10.4	2.07
	31	5.29	0.91	6.31	1.12	7.33	1.36	7.84	1.49	8.35	1.62	9.37	1.90	10.4	2.21
	33	5.29	0.96	6.31	1.19	7.33	1.44	7.84	1.58	8.35	1.72	9.37	2.03	10.4	2.36
35	5.29	1.02	6.31	1.26	7.33	1.54	7.84	1.68	8.35	1.83	9.37	2.16	10.4	2.51	
37	5.29	1.08	6.31	1.34	7.33	1.63	7.84	1.79	8.35	1.95	9.37	2.30	10.4	2.67	
39	5.29	1.14	6.31	1.42	7.33	1.73	7.84	1.90	8.35	2.07	9.37	2.44	10.4	2.85	
60% 6.72 kW (60.0)	10	4.54	0.59	5.41	0.69	6.28	0.80	6.72	0.86	7.16	0.91	8.03	1.03	8.90	1.16
	12	4.54	0.60	5.41	0.70	6.28	0.81	6.72	0.87	7.16	0.93	8.03	1.05	8.90	1.18
	14	4.54	0.61	5.41	0.71	6.28	0.83	6.72	0.89	7.16	0.95	8.03	1.07	8.90	1.20
	16	4.54	0.61	5.41	0.72	6.28	0.84	6.72	0.90	7.16	0.96	8.03	1.09	8.90	1.22
	18	4.54	0.62	5.41	0.74	6.28	0.85	6.72	0.92	7.16	0.98	8.03	1.11	8.90	1.25
	20	4.54	0.63	5.41	0.75	6.28	0.87	6.72	0.93	7.16	1.00	8.03	1.13	8.90	1.27
	21	4.54	0.64	5.41	0.75	6.28	0.88	6.72	0.94	7.16	1.01	8.03	1.14	8.90	1.28
	23	4.54	0.65	5.41	0.77	6.28	0.89	6.72	0.96	7.16	1.03	8.03	1.19	8.90	1.37
	25	4.54	0.66	5.41	0.78	6.28	0.93	6.72	1.01	7.16	1.09	8.03	1.27	8.90	1.46
	27	4.54	0.68	5.41	0.83	6.28	0.99	6.72	1.07	7.16	1.16	8.03	1.35	8.90	1.56
	29	4.54	0.72	5.41	0.88	6.28	1.05	6.72	1.14	7.16	1.24	8.03	1.44	8.90	1.66
	31	4.54	0.77	5.41	0.93	6.28	1.12	6.72	1.21	7.16	1.32	8.03	1.54	8.90	1.77
	33	4.54	0.81	5.41	0.99	6.28	1.19	6.72	1.29	7.16	1.40	8.03	1.63	8.90	1.89
35	4.54	0.86	5.41	1.05	6.28	1.26	6.72	1.37	7.16	1.49	8.03	1.74	8.90	2.01	
37	4.54	0.91	5.41	1.11	6.28	1.33	6.72	1.45	7.16	1.58	8.03	1.85	8.90	2.13	
39	4.54	0.96	5.41	1.17	6.28	1.41	6.72	1.54	7.16	1.68	8.03	1.96	8.90	2.27	
50% 5.60 kW (50.0)	10	3.78	0.51	4.51	0.59	5.24	0.67	5.60	0.71	5.96	0.76	6.69	0.85	7.42	0.95
	12	3.78	0.51	4.51	0.59	5.24	0.68	5.60	0.73	5.96	0.77	6.69	0.87	7.42	0.97
	14	3.78	0.52	4.51	0.60	5.24	0.69	5.60	0.74	5.96	0.78	6.69	0.88	7.42	0.98
	16	3.78	0.53	4.51	0.61	5.24	0.70	5.60	0.75	5.96	0.80	6.69	0.90	7.42	1.00
	18	3.78	0.53	4.51	0.62	5.24	0.71	5.60	0.76	5.96	0.81	6.69	0.91	7.42	1.02
	20	3.78	0.54	4.51	0.63	5.24	0.73	5.60	0.77	5.96	0.83	6.69	0.93	7.42	1.04
	21	3.78	0.55	4.51	0.64	5.24	0.73	5.60	0.78	5.96	0.83	6.69	0.94	7.42	1.05
	23	3.78	0.55	4.51	0.65	5.24	0.74	5.60	0.80	5.96	0.85	6.69	0.96	7.42	1.07
	25	3.78	0.56	4.51	0.66	5.24	0.76	5.60	0.81	5.96	0.87	6.69	1.00	7.42	1.14
	27	3.78	0.57	4.51	0.68	5.24	0.80	5.60	0.86	5.96	0.93	6.69	1.07	7.42	1.22
	29	3.78	0.60	4.51	0.72	5.24	0.85	5.60	0.92	5.96	0.99	6.69	1.14	7.42	1.30
	31	3.78	0.64	4.51	0.76	5.24	0.90	5.60	0.97	5.96	1.05	6.69	1.21	7.42	1.38
	33	3.78	0.67	4.51	0.81	5.24	0.95	5.60	1.03	5.96	1.11	6.69	1.28	7.42	1.47
35	3.78	0.71	4.51	0.85	5.24	1.01	5.60	1.09	5.96	1.18	6.69	1.36	7.42	1.56	
37	3.78	0.75	4.51	0.90	5.24	1.07	5.60	1.16	5.96	1.25	6.69	1.45	7.42	1.66	
39	3.78	0.79	4.51	0.95	5.24	1.13	5.60	1.22	5.96	1.32	6.69	1.53	7.42	1.76	

4TW32002-2

7 Capacity tables

7 - 1 Cooling Capacity Tables

7

ERQ125AV1

Cooling

TC: Total capacity, kW; PI: Power Input, kW (Comp. + Outdoor fan motor)

Combination % kW (Capacity index)	Outdoor air temp. (°CDB)	Indoor air temp. °CWB													
		14.0 °CWB		16.0 °CWB		18.0 °CWB		19.0 °CWB		20.0 °CWB		22.0 °CWB		24.0 °CWB	
		20.0 °CDB	23.0 °CDB	26.0 °CDB	27.0 °CDB	28.0 °CDB	30.0 °CDB	32.0 °CDB	TC	PI	TC	PI	TC	PI	TC
70% 9.80 kW (87.5)	10	6.61	0.84	7.89	1.00	9.16	1.17	9.80	1.26	10.4	1.35	11.7	1.53	13.0	1.72
	12	6.61	0.86	7.89	1.02	9.16	1.19	9.80	1.28	10.4	1.37	11.7	1.56	13.0	1.75
	14	6.61	0.87	7.89	1.04	9.16	1.21	9.80	1.30	10.4	1.40	11.7	1.59	13.0	1.79
	16	6.61	0.89	7.89	1.05	9.16	1.23	9.80	1.33	10.4	1.42	11.7	1.62	13.0	1.82
	18	6.61	0.90	7.89	1.07	9.16	1.26	9.80	1.35	10.4	1.45	11.7	1.65	13.0	1.86
	20	6.61	0.91	7.89	1.09	9.16	1.28	9.80	1.38	10.4	1.48	11.7	1.68	13.0	1.91
	21	6.61	0.92	7.89	1.10	9.16	1.29	9.80	1.39	10.4	1.49	11.7	1.71	13.0	1.98
	23	6.61	0.94	7.89	1.12	9.16	1.32	9.80	1.44	10.4	1.56	11.7	1.83	13.0	2.12
	25	6.61	0.96	7.89	1.17	9.16	1.41	9.80	1.54	10.4	1.67	11.7	1.96	13.0	2.27
	27	6.61	1.01	7.89	1.24	9.16	1.50	9.80	1.64	10.4	1.78	11.7	2.09	13.0	2.42
	29	6.61	1.07	7.89	1.32	9.16	1.60	9.80	1.74	10.4	1.90	11.7	2.23	13.0	2.59
	31	6.61	1.14	7.89	1.40	9.16	1.70	9.80	1.86	10.4	2.02	11.7	2.38	13.0	2.76
	33	6.61	1.20	7.89	1.49	9.16	1.80	9.80	1.97	10.4	2.15	11.7	2.53	13.0	2.94
35	6.61	1.28	7.89	1.58	9.16	1.92	9.80	2.10	10.4	2.29	11.7	2.70	13.0	3.14	
37	6.61	1.35	7.89	1.68	9.16	2.04	9.80	2.23	10.4	2.43	11.7	2.87	13.0	3.34	
39	6.61	1.43	7.89	1.78	9.16	2.16	9.80	2.37	10.4	2.59	11.7	3.05	13.0	3.56	
60% 8.40 kW (75.0)	10	5.67	0.74	6.76	0.86	7.85	1.00	8.40	1.07	8.95	1.14	10.0	1.29	11.1	1.45
	12	5.67	0.75	6.76	0.88	7.85	1.01	8.40	1.09	8.95	1.16	10.0	1.31	11.1	1.47
	14	5.67	0.76	6.76	0.89	7.85	1.03	8.40	1.11	8.95	1.18	10.0	1.34	11.1	1.50
	16	5.67	0.77	6.76	0.90	7.85	1.05	8.40	1.13	8.95	1.20	10.0	1.36	11.1	1.53
	18	5.67	0.78	6.76	0.92	7.85	1.07	8.40	1.15	8.95	1.22	10.0	1.39	11.1	1.56
	20	5.67	0.79	6.76	0.93	7.85	1.09	8.40	1.17	8.95	1.25	10.0	1.42	11.1	1.59
	21	5.67	0.80	6.76	0.94	7.85	1.10	8.40	1.18	8.95	1.26	10.0	1.43	11.1	1.60
	23	5.67	0.81	6.76	0.96	7.85	1.12	8.40	1.20	8.95	1.28	10.0	1.48	11.1	1.71
	25	5.67	0.82	6.76	0.98	7.85	1.16	8.40	1.26	8.95	1.36	10.0	1.59	11.1	1.82
	27	5.67	0.85	6.76	1.04	7.85	1.24	8.40	1.34	8.95	1.45	10.0	1.69	11.1	1.95
	29	5.67	0.91	6.76	1.10	7.85	1.31	8.40	1.43	8.95	1.55	10.0	1.80	11.1	2.07
	31	5.67	0.96	6.76	1.17	7.85	1.39	8.40	1.52	8.95	1.65	10.0	1.92	11.1	2.21
	33	5.67	1.01	6.76	1.24	7.85	1.48	8.40	1.61	8.95	1.75	10.0	2.04	11.1	2.35
35	5.67	1.07	6.76	1.31	7.85	1.57	8.40	1.71	8.95	1.86	10.0	2.17	11.1	2.51	
37	5.67	1.13	6.76	1.39	7.85	1.67	8.40	1.82	8.95	1.97	10.0	2.31	11.1	2.67	
39	5.67	1.20	6.76	1.47	7.85	1.77	8.40	1.93	8.95	2.09	10.0	2.45	11.1	2.84	
50% 7.00 kW (62.5)	10	4.72	0.63	5.63	0.73	6.54	0.84	7.00	0.89	7.46	0.95	8.37	1.06	9.28	1.19
	12	4.72	0.64	5.63	0.74	6.54	0.85	7.00	0.91	7.46	0.96	8.37	1.08	9.28	1.21
	14	4.72	0.65	5.63	0.75	6.54	0.86	7.00	0.92	7.46	0.98	8.37	1.10	9.28	1.23
	16	4.72	0.66	5.63	0.76	6.54	0.88	7.00	0.94	7.46	1.00	8.37	1.12	9.28	1.25
	18	4.72	0.67	5.63	0.78	6.54	0.89	7.00	0.95	7.46	1.01	8.37	1.14	9.28	1.27
	20	4.72	0.68	5.63	0.79	6.54	0.91	7.00	0.97	7.46	1.03	8.37	1.16	9.28	1.30
	21	4.72	0.68	5.63	0.79	6.54	0.91	7.00	0.98	7.46	1.04	8.37	1.17	9.28	1.31
	23	4.72	0.69	5.63	0.81	6.54	0.93	7.00	0.99	7.46	1.06	8.37	1.19	9.28	1.34
	25	4.72	0.70	5.63	0.82	6.54	0.95	7.00	1.01	7.46	1.09	8.37	1.25	9.28	1.43
	27	4.72	0.71	5.63	0.85	6.54	1.00	7.00	1.08	7.46	1.16	8.37	1.34	9.28	1.52
	29	4.72	0.75	5.63	0.90	6.54	1.06	7.00	1.14	7.46	1.23	8.37	1.42	9.28	1.62
	31	4.72	0.80	5.63	0.95	6.54	1.12	7.00	1.21	7.46	1.31	8.37	1.51	9.28	1.73
	33	4.72	0.84	5.63	1.01	6.54	1.19	7.00	1.29	7.46	1.39	8.37	1.60	9.28	1.83
35	4.72	0.89	5.63	1.07	6.54	1.26	7.00	1.36	7.46	1.47	8.37	1.70	9.28	1.95	
37	4.72	0.94	5.63	1.13	6.54	1.33	7.00	1.44	7.46	1.56	8.37	1.81	9.28	2.07	
39	4.72	0.99	5.63	1.19	6.54	1.41	7.00	1.53	7.46	1.65	8.37	1.92	9.28	2.20	

4TW32002-2

7 Capacity tables

7 - 1 Cooling Capacity Tables

ERQ140AV1

Cooling

TC: Total capacity, kW; PI: Power Input, kW (Comp. + Outdoor fan motor)

Combination % kW (Capacity index)	Outdoor air temp. (°CDB)	Indoor air temp. °CWB													
		14.0 °CWB		16.0 °CWB		18.0 °CWB		19.0 °CWB		20.0 °CWB		22.0 °CWB		24.0 °CWB	
		20.0 °CDB		23.0 °CDB		26.0 °CDB		27.0 °CDB		28.0 °CDB		30.0 °CDB		32.0 °CDB	
		TC	PI	TC	PI	TC	PI	TC	PI	TC	PI	TC	PI	TC	PI
70% 10.85 kW (105.0)	10	7.32	1.09	8.73	1.29	10.1	1.51	10.9	1.62	11.6	1.74	13.0	1.98	14.4	2.22
	12	7.32	1.11	8.73	1.32	10.1	1.54	10.9	1.65	11.6	1.77	13.0	2.01	14.4	2.26
	14	7.32	1.12	8.73	1.34	10.1	1.56	10.9	1.68	11.6	1.80	13.0	2.05	14.4	2.31
	16	7.32	1.14	8.73	1.36	10.1	1.59	10.9	1.71	11.6	1.84	13.0	2.09	14.4	2.35
	18	7.32	1.16	8.73	1.38	10.1	1.62	10.9	1.74	11.6	1.87	13.0	2.13	14.4	2.40
	20	7.32	1.18	8.73	1.41	10.1	1.65	10.9	1.78	11.6	1.91	13.0	2.17	14.4	2.46
	21	7.32	1.19	8.73	1.42	10.1	1.67	10.9	1.80	11.6	1.93	13.0	2.21	14.4	2.55
	23	7.32	1.21	8.73	1.45	10.1	1.70	10.9	1.86	11.6	2.02	13.0	2.36	14.4	2.73
	25	7.32	1.23	8.73	1.51	10.1	1.82	10.9	1.98	11.6	2.16	13.0	2.52	14.4	2.92
	27	7.32	1.30	8.73	1.60	10.1	1.93	10.9	2.11	11.6	2.30	13.0	2.70	14.4	3.13
	29	7.32	1.38	8.73	1.70	10.1	2.06	10.9	2.25	11.6	2.45	13.0	2.88	14.4	3.34
	31	7.32	1.47	8.73	1.81	10.1	2.19	10.9	2.40	11.6	2.61	13.0	3.07	14.4	3.56
	33	7.32	1.55	8.73	1.92	10.1	2.33	10.9	2.55	11.6	2.78	13.0	3.27	14.4	3.80
35	7.32	1.65	8.73	2.04	10.1	2.47	10.9	2.71	11.6	2.95	13.0	3.48	14.4	4.05	
37	7.32	1.74	8.73	2.16	10.1	2.63	10.9	2.88	11.6	3.14	13.0	3.70	14.4	4.31	
39	7.32	1.84	8.73	2.29	10.1	2.79	10.9	3.06	11.6	3.34	13.0	3.94	14.4	4.59	
60% 9.30 kW (90.0)	10	6.28	0.95	7.49	1.11	8.70	1.29	9.30	1.38	9.90	1.47	11.1	1.67	12.3	1.87
	12	6.28	0.96	7.49	1.13	8.70	1.31	9.30	1.40	9.90	1.50	11.1	1.70	12.3	1.90
	14	6.28	0.98	7.49	1.15	8.70	1.33	9.30	1.43	9.90	1.52	11.1	1.73	12.3	1.94
	16	6.28	0.99	7.49	1.17	8.70	1.35	9.30	1.45	9.90	1.55	11.1	1.76	12.3	1.97
	18	6.28	1.01	7.49	1.19	8.70	1.38	9.30	1.48	9.90	1.58	11.1	1.79	12.3	2.01
	20	6.28	1.02	7.49	1.21	8.70	1.40	9.30	1.51	9.90	1.61	11.1	1.83	12.3	2.05
	21	6.28	1.03	7.49	1.22	8.70	1.42	9.30	1.52	9.90	1.63	11.1	1.84	12.3	2.07
	23	6.28	1.05	7.49	1.24	8.70	1.44	9.30	1.55	9.90	1.66	11.1	1.92	12.3	2.20
	25	6.28	1.06	7.49	1.26	8.70	1.50	9.30	1.63	9.90	1.76	11.1	2.05	12.3	2.35
	27	6.28	1.10	7.49	1.34	8.70	1.59	9.30	1.73	9.90	1.88	11.1	2.18	12.3	2.51
	29	6.28	1.17	7.49	1.42	8.70	1.69	9.30	1.84	9.90	2.00	11.1	2.32	12.3	2.68
	31	6.28	1.24	7.49	1.50	8.70	1.80	9.30	1.96	9.90	2.12	11.1	2.47	12.3	2.85
	33	6.28	1.31	7.49	1.60	8.70	1.91	9.30	2.08	9.90	2.26	11.1	2.63	12.3	3.04
35	6.28	1.38	7.49	1.69	8.70	2.03	9.30	2.21	9.90	2.40	11.1	2.80	12.3	3.23	
37	6.28	1.46	7.49	1.79	8.70	2.15	9.30	2.34	9.90	2.55	11.1	2.98	12.3	3.44	
39	6.28	1.55	7.49	1.89	8.70	2.28	9.30	2.49	9.90	2.70	11.1	3.16	12.3	3.66	
50% 7.75 kW (75.0)	10	5.23	0.82	6.24	0.94	7.25	1.08	7.75	1.15	8.25	1.22	9.26	1.37	10.3	1.53
	12	5.23	0.83	6.24	0.96	7.25	1.10	7.75	1.17	8.25	1.24	9.26	1.40	10.3	1.56
	14	5.23	0.84	6.24	0.97	7.25	1.11	7.75	1.19	8.25	1.26	9.26	1.42	10.3	1.58
	16	5.23	0.85	6.24	0.99	7.25	1.13	7.75	1.21	8.25	1.28	9.26	1.45	10.3	1.61
	18	5.23	0.86	6.24	1.00	7.25	1.15	7.75	1.23	8.25	1.31	9.26	1.47	10.3	1.64
	20	5.23	0.87	6.24	1.02	7.25	1.17	7.75	1.25	8.25	1.33	9.26	1.50	10.3	1.67
	21	5.23	0.88	6.24	1.02	7.25	1.18	7.75	1.26	8.25	1.34	9.26	1.51	10.3	1.69
	23	5.23	0.89	6.24	1.04	7.25	1.20	7.75	1.28	8.25	1.37	9.26	1.54	10.3	1.73
	25	5.23	0.91	6.24	1.06	7.25	1.22	7.75	1.31	8.25	1.41	9.26	1.62	10.3	1.84
	27	5.23	0.92	6.24	1.10	7.25	1.29	7.75	1.39	8.25	1.50	9.26	1.72	10.3	1.97
	29	5.23	0.97	6.24	1.16	7.25	1.37	7.75	1.48	8.25	1.59	9.26	1.83	10.3	2.09
	31	5.23	1.03	6.24	1.23	7.25	1.45	7.75	1.57	8.25	1.69	9.26	1.95	10.3	2.23
	33	5.23	1.09	6.24	1.30	7.25	1.54	7.75	1.66	8.25	1.79	9.26	2.07	10.3	2.37
35	5.23	1.15	6.24	1.37	7.25	1.63	7.75	1.76	8.25	1.90	9.26	2.20	10.3	2.52	
37	5.23	1.21	6.24	1.45	7.25	1.72	7.75	1.86	8.25	2.01	9.26	2.33	10.3	2.67	
39	5.23	1.27	6.24	1.53	7.25	1.82	7.75	1.97	8.25	2.13	9.26	2.47	10.3	2.84	

4TW32002-2

7 Capacity tables

7 - 2 Heating Capacity Tables

ERQ100AV1

Heating

TC: Total capacity; kW; PI: Power Input; kW (Comp. + Outdoor fan motor)

Combination % kW (Capacity index)	Outdoor air temp.		Indoor air temp. °CWB											
			16.0		18.0		20.0		21.0		22.0		24.0	
			TC	PI	TC	PI	TC	PI	TC	PI	TC	PI	TC	PI
	°CDB	°CWB	kW	kW	kW	kW	kW	kW	kW	kW	kW	kW	kW	kW
70% 8.75 kW (70.0)	-19.8	-20.0	9.87	4.27	9.31	3.96	8.75	3.66	8.47	3.51	8.19	3.36	7.63	3.08
	-18.8	-19.0	9.87	4.10	9.31	3.80	8.75	3.52	8.47	3.38	8.19	3.24	7.63	2.97
	-16.7	-17.0	9.87	3.80	9.31	3.53	8.75	3.27	8.47	3.14	8.19	3.01	7.63	2.76
	-14.7	-15.0	9.87	3.55	9.31	3.30	8.75	3.05	8.47	2.93	8.19	2.82	7.63	2.59
	-12.6	-13.0	9.87	3.32	9.31	3.09	8.75	2.86	8.47	2.75	8.19	2.64	7.63	2.43
	-10.5	-11.0	9.87	3.12	9.31	2.91	8.75	2.70	8.47	2.59	8.19	2.49	7.63	2.30
	-9.5	-10.0	9.87	3.03	9.31	2.82	8.75	2.62	8.47	2.52	8.19	2.42	7.63	2.23
	-8.5	-9.1	9.87	2.96	9.31	2.75	8.75	2.56	8.47	2.46	8.19	2.37	7.63	2.18
	-7.0	-7.6	9.87	2.84	9.31	2.64	8.75	2.46	8.47	2.37	8.19	2.27	7.63	2.10
	-5.0	-5.6	9.87	2.69	9.31	2.51	8.75	2.34	8.47	2.25	8.19	2.16	7.63	2.00
	-3.0	-3.7	9.87	2.57	9.31	2.40	8.75	2.23	8.47	2.15	8.19	2.07	7.63	1.91
	0.0	-0.7	9.87	2.39	9.31	2.24	8.75	2.08	8.47	2.01	8.19	1.94	7.63	1.79
	3.0	2.2	9.87	2.25	9.31	2.10	8.75	1.96	8.47	1.89	8.19	1.82	7.63	1.69
	5.0	4.1	9.87	2.16	9.31	2.02	8.75	1.89	8.47	1.82	8.19	1.76	7.63	1.63
	7.0	6.0	9.87	2.08	9.31	1.95	8.75	1.82	8.47	1.76	8.19	1.70	7.63	1.57
	9.0	7.9	9.87	2.01	9.31	1.88	8.75	1.76	8.47	1.70	8.19	1.64	7.63	1.52
11.0	9.8	9.87	1.94	9.31	1.82	8.75	1.70	8.47	1.65	8.19	1.59	7.63	1.47	
13.0	11.8	9.87	1.88	9.31	1.76	8.75	1.65	8.47	1.59	8.19	1.54	7.63	1.43	
15.0	13.7	9.87	1.82	9.31	1.71	8.75	1.60	8.47	1.54	8.19	1.49	7.63	1.39	
60% 7.50 kW (60.0)	-19.8	-20.0	8.46	3.51	7.98	3.26	7.50	3.02	7.26	2.90	7.02	2.78	6.54	2.56
	-18.8	-19.0	8.46	3.37	7.98	3.14	7.50	2.91	7.26	2.79	7.02	2.68	6.54	2.47
	-16.7	-17.0	8.46	3.14	7.98	2.92	7.50	2.71	7.26	2.61	7.02	2.50	6.54	2.30
	-14.7	-15.0	8.46	2.93	7.98	2.73	7.50	2.54	7.26	2.44	7.02	2.35	6.54	2.16
	-12.6	-13.0	8.46	2.75	7.98	2.57	7.50	2.39	7.26	2.30	7.02	2.21	6.54	2.04
	-10.5	-11.0	8.46	2.59	7.98	2.42	7.50	2.25	7.26	2.17	7.02	2.09	6.54	1.93
	-9.5	-10.0	8.46	2.52	7.98	2.35	7.50	2.19	7.26	2.11	7.02	2.03	6.54	1.88
	-8.5	-9.1	8.46	2.46	7.98	2.30	7.50	2.14	7.26	2.06	7.02	1.99	6.54	1.84
	-7.0	-7.6	8.46	2.36	7.98	2.21	7.50	2.06	7.26	1.98	7.02	1.91	6.54	1.77
	-5.0	-5.6	8.46	2.25	7.98	2.10	7.50	1.96	7.26	1.89	7.02	1.82	6.54	1.69
	-3.0	-3.7	8.46	2.15	7.98	2.01	7.50	1.88	7.26	1.81	7.02	1.75	6.54	1.62
	0.0	-0.7	8.46	2.01	7.98	1.88	7.50	1.76	7.26	1.70	7.02	1.64	6.54	1.52
	3.0	2.2	8.46	1.89	7.98	1.77	7.50	1.66	7.26	1.60	7.02	1.55	6.54	1.44
	5.0	4.1	8.46	1.82	7.98	1.71	7.50	1.60	7.26	1.55	7.02	1.49	6.54	1.39
	7.0	6.0	8.46	1.76	7.98	1.65	7.50	1.55	7.26	1.49	7.02	1.44	6.54	1.34
	9.0	7.9	8.46	1.70	7.98	1.60	7.50	1.50	7.26	1.45	7.02	1.40	6.54	1.30
11.0	9.8	8.46	1.64	7.98	1.55	7.50	1.45	7.26	1.40	7.02	1.35	6.54	1.26	
13.0	11.8	8.46	1.59	7.98	1.50	7.50	1.40	7.26	1.36	7.02	1.31	6.54	1.22	
15.0	13.7	8.46	1.54	7.98	1.45	7.50	1.36	7.26	1.32	7.02	1.28	6.54	1.19	
50% 6.25 kW (50.0)	-19.8	-20.0	7.05	2.80	6.65	2.61	6.25	2.43	6.05	2.34	5.85	2.25	5.45	2.07
	-18.8	-19.0	7.05	2.70	6.65	2.52	6.25	2.34	6.05	2.26	5.85	2.17	5.45	2.00
	-16.7	-17.0	7.05	2.52	6.65	2.35	6.25	2.19	6.05	2.11	5.85	2.03	5.45	1.88
	-14.7	-15.0	7.05	2.36	6.65	2.21	6.25	2.06	6.05	1.98	5.85	1.91	5.45	1.77
	-12.6	-13.0	7.05	2.22	6.65	2.08	6.25	1.94	6.05	1.87	5.85	1.80	5.45	1.67
	-10.5	-11.0	7.05	2.10	6.65	1.97	6.25	1.84	6.05	1.77	5.85	1.71	5.45	1.58
	-9.5	-10.0	7.05	2.04	6.65	1.92	6.25	1.79	6.05	1.73	5.85	1.67	5.45	1.54
	-8.5	-9.1	7.05	2.00	6.65	1.87	6.25	1.75	6.05	1.69	5.85	1.63	5.45	1.51
	-7.0	-7.6	7.05	1.92	6.65	1.80	6.25	1.69	6.05	1.63	5.85	1.57	5.45	1.46
	-5.0	-5.6	7.05	1.83	6.65	1.72	6.25	1.61	6.05	1.55	5.85	1.50	5.45	1.39
	-3.0	-3.7	7.05	1.75	6.65	1.65	6.25	1.54	6.05	1.49	5.85	1.44	5.45	1.34
	0.0	-0.7	7.05	1.65	6.65	1.55	6.25	1.45	6.05	1.40	5.85	1.36	5.45	1.26
	3.0	2.2	7.05	1.55	6.65	1.46	6.25	1.37	6.05	1.33	5.85	1.28	5.45	1.20
	5.0	4.1	7.05	1.50	6.65	1.41	6.25	1.33	6.05	1.28	5.85	1.24	5.45	1.16
	7.0	6.0	7.05	1.45	6.65	1.37	6.25	1.28	6.05	1.24	5.85	1.20	5.45	1.12
	9.0	7.9	7.05	1.40	6.65	1.32	6.25	1.24	6.05	1.21	5.85	1.17	5.45	1.09
11.0	9.8	7.05	1.36	6.65	1.28	6.25	1.21	6.05	1.17	5.85	1.13	5.45	1.06	
13.0	11.8	7.05	1.32	6.65	1.24	6.25	1.17	6.05	1.14	5.85	1.10	5.45	1.03	
15.0	13.7	7.05	1.28	6.65	1.21	6.25	1.14	6.05	1.10	5.85	1.07	5.45	1.00	

4TW32002-3

7 Capacity tables

7 - 2 Heating Capacity Tables

ERQ125AV1

Heating

TC: Total capacity; kW; PI: Power Input; kW (Comp. + Outdoor fan motor)

Combination % kW (Capacity index)	Outdoor air temp.		Indoor air temp. °CWB											
			16.0		18.0		20.0		21.0		22.0		24.0	
			TC	PI	TC	PI	TC	PI	TC	PI	TC	PI	TC	PI
	°CDB	°CWB												
70% 11.20 kW (87.5)	-19.8	-20.0	10.77	4.61	10.75	4.71	10.73	4.81	10.72	4.86	10.48	4.74	9.76	4.34
	-18.8	-19.0	11.10	4.66	11.08	4.76	11.06	4.86	10.84	4.76	10.48	4.56	9.76	4.18
	-16.7	-17.0	11.76	4.76	11.74	4.86	11.20	4.60	10.84	4.42	10.48	4.24	9.76	3.89
	-14.7	-15.0	12.42	4.86	11.92	4.64	11.20	4.30	10.84	4.13	10.48	3.97	9.76	3.64
	-12.6	-13.0	12.64	4.68	11.92	4.35	11.20	4.03	10.84	3.88	10.48	3.73	9.76	3.43
	-10.5	-11.0	12.64	4.40	11.92	4.10	11.20	3.80	10.84	3.66	10.48	3.51	9.76	3.23
	-9.5	-10.0	12.64	4.27	11.92	3.98	11.20	3.69	10.84	3.55	10.48	3.42	9.76	3.15
	-8.5	-9.1	12.64	4.16	11.92	3.88	11.20	3.60	10.84	3.47	10.48	3.33	9.76	3.07
	-7.0	-7.6	12.64	3.99	11.92	3.72	11.20	3.46	10.84	3.33	10.48	3.20	9.76	2.96
	-5.0	-5.6	12.64	3.79	11.92	3.54	11.20	3.29	10.84	3.17	10.48	3.05	9.76	2.81
	-3.0	-3.7	12.64	3.62	11.92	3.38	11.20	3.14	10.84	3.03	10.48	2.91	9.76	2.69
	0.0	-0.7	12.64	3.37	11.92	3.15	11.20	2.94	10.84	2.83	10.48	2.73	9.76	2.52
	3.0	2.2	12.64	3.17	11.92	2.96	11.20	2.76	10.84	2.67	10.48	2.57	9.76	2.38
	5.0	4.1	12.64	3.05	11.92	2.85	11.20	2.66	10.84	2.57	10.48	2.48	9.76	2.29
	7.0	6.0	12.64	2.94	11.92	2.75	11.20	2.57	10.84	2.48	10.48	2.39	9.76	2.22
	9.0	7.9	12.64	2.83	11.92	2.66	11.20	2.48	10.84	2.40	10.48	2.31	9.76	2.14
11.0	9.8	12.64	2.74	11.92	2.57	11.20	2.40	10.84	2.32	10.48	2.24	9.76	2.08	
13.0	11.8	12.64	2.65	11.92	2.48	11.20	2.32	10.84	2.24	10.48	2.16	9.76	2.01	
15.0	13.7	12.64	2.56	11.92	2.41	11.20	2.25	10.84	2.18	10.48	2.10	9.76	1.95	
60% 9.60 kW (75.0)	-19.8	-20.0	10.72	4.86	10.22	4.59	9.60	4.25	9.29	4.09	8.98	3.92	8.37	3.60
	-18.8	-19.0	10.83	4.75	10.22	4.42	9.60	4.10	9.29	3.94	8.98	3.78	8.37	3.48
	-16.7	-17.0	10.83	4.42	10.22	4.11	9.60	3.82	9.29	3.67	8.98	3.53	8.37	3.25
	-14.7	-15.0	10.83	4.13	10.22	3.85	9.60	3.57	9.29	3.44	8.98	3.31	8.37	3.05
	-12.6	-13.0	10.83	3.88	10.22	3.61	9.60	3.36	9.29	3.24	8.98	3.11	8.37	2.87
	-10.5	-11.0	10.83	3.65	10.22	3.41	9.60	3.17	9.29	3.06	8.98	2.94	8.37	2.72
	-9.5	-10.0	10.83	3.55	10.22	3.32	9.60	3.09	9.29	2.97	8.98	2.86	8.37	2.65
	-8.5	-9.1	10.83	3.46	10.22	3.24	9.60	3.01	9.29	2.90	8.98	2.80	8.37	2.59
	-7.0	-7.6	10.83	3.33	10.22	3.11	9.60	2.90	9.29	2.80	8.98	2.69	8.37	2.49
	-5.0	-5.6	10.83	3.17	10.22	2.96	9.60	2.76	9.29	2.66	8.98	2.57	8.37	2.38
	-3.0	-3.7	10.83	3.03	10.22	2.83	9.60	2.64	9.29	2.55	8.98	2.46	8.37	2.28
	0.0	-0.7	10.83	2.83	10.22	2.65	9.60	2.48	9.29	2.39	8.98	2.31	8.37	2.14
	3.0	2.2	10.83	2.66	10.22	2.50	9.60	2.34	9.29	2.26	8.98	2.18	8.37	2.02
	5.0	4.1	10.83	2.57	10.22	2.41	9.60	2.25	9.29	2.18	8.98	2.10	8.37	1.96
	7.0	6.0	10.83	2.48	10.22	2.33	9.60	2.18	9.29	2.11	8.98	2.03	8.37	1.89
	9.0	7.9	10.83	2.39	10.22	2.25	9.60	2.11	9.29	2.04	8.98	1.97	8.37	1.83
11.0	9.8	10.83	2.32	10.22	2.18	9.60	2.04	9.29	1.97	8.98	1.91	8.37	1.78	
13.0	11.8	10.83	2.24	10.22	2.11	9.60	1.98	9.29	1.91	8.98	1.85	8.37	1.72	
15.0	13.7	10.83	2.17	10.22	2.05	9.60	1.92	9.29	1.86	8.98	1.80	8.37	1.68	
50% 8.00 kW (62.5)	-19.8	-20.0	9.03	3.95	8.51	3.68	8.00	3.42	7.74	3.29	7.49	3.17	6.97	2.92
	-18.8	-19.0	9.03	3.80	8.51	3.55	8.00	3.30	7.74	3.18	7.49	3.06	6.97	2.82
	-16.7	-17.0	9.03	3.55	8.51	3.31	8.00	3.08	7.74	2.97	7.49	2.86	6.97	2.64
	-14.7	-15.0	9.03	3.33	8.51	3.11	8.00	2.90	7.74	2.79	7.49	2.69	6.97	2.49
	-12.6	-13.0	9.03	3.13	8.51	2.93	8.00	2.73	7.74	2.64	7.49	2.54	6.97	2.35
	-10.5	-11.0	9.03	2.96	8.51	2.77	8.00	2.59	7.74	2.50	7.49	2.41	6.97	2.23
	-9.5	-10.0	9.03	2.88	8.51	2.70	8.00	2.52	7.74	2.43	7.49	2.35	6.97	2.18
	-8.5	-9.1	9.03	2.81	8.51	2.64	8.00	2.46	7.74	2.38	7.49	2.29	6.97	2.13
	-7.0	-7.6	9.03	2.71	8.51	2.54	8.00	2.37	7.74	2.29	7.49	2.21	6.97	2.05
	-5.0	-5.6	9.03	2.58	8.51	2.42	8.00	2.27	7.74	2.19	7.49	2.11	6.97	1.96
	-3.0	-3.7	9.03	2.47	8.51	2.32	8.00	2.17	7.74	2.10	7.49	2.03	6.97	1.89
	0.0	-0.7	9.03	2.32	8.51	2.18	8.00	2.04	7.74	1.98	7.49	1.91	6.97	1.78
	3.0	2.2	9.03	2.19	8.51	2.06	8.00	1.93	7.74	1.87	7.49	1.81	6.97	1.69
	5.0	4.1	9.03	2.11	8.51	1.99	8.00	1.87	7.74	1.81	7.49	1.75	6.97	1.63
	7.0	6.0	9.03	2.04	8.51	1.93	8.00	1.81	7.74	1.75	7.49	1.69	6.97	1.58
	9.0	7.9	9.03	1.98	8.51	1.86	8.00	1.75	7.74	1.70	7.49	1.64	6.97	1.54
11.0	9.8	9.03	1.92	8.51	1.81	8.00	1.70	7.74	1.65	7.49	1.60	6.97	1.49	
13.0	11.8	9.03	1.86	8.51	1.75	8.00	1.65	7.74	1.60	7.49	1.55	6.97	1.45	
15.0	13.7	9.03	1.81	8.51	1.70	8.00	1.61	7.74	1.56	7.49	1.51	6.97	1.41	

4TW32002-3

7 Capacity tables

7 - 2 Heating Capacity Tables

ERQ140AV1

Heating

TC: Total capacity; kW; PI: Power Input; kW (Comp. + Outdoor fan motor)

Combination % kW (Capacity index)	Outdoor air temp.		Indoor air temp. °CWB														
			16.0		18.0		20.0		21.0		22.0		24.0				
			TC	PI	TC	PI	TC	PI	TC	PI	TC	PI	TC	PI			
100% 18.00 kW (150.0)	°CDB	°CWB															
	-19.8	-20.0	11.1	3.70	11.1	3.87	11.1	4.03	11.1	4.12	11.0	4.20	11.0	4.37	11.0	4.37	
	-18.8	-19.0	11.5	3.79	11.4	3.95	11.4	4.12	11.4	4.20	11.4	4.28	11.3	4.44			
	-16.7	-17.0	12.1	3.96	12.1	4.11	12.1	4.27	12.1	4.34	12.0	4.42	12.0	4.58			
	-14.7	-15.0	12.8	4.11	12.8	4.26	12.7	4.40	12.7	4.47	12.7	4.55	12.7	4.69			
	-12.6	-13.0	13.5	4.25	13.4	4.38	13.4	4.52	13.4	4.59	13.4	4.66	13.3	4.80			
	-10.5	-11.0	14.1	4.37	14.1	4.50	14.1	4.63	14.1	4.70	14.0	4.76	14.0	4.90			
	-9.5	-10.0	14.5	4.43	14.4	4.56	14.4	4.68	14.4	4.75	14.4	4.81	14.3	4.94			
	-8.5	-9.1	14.8	4.48	14.7	4.60	14.7	4.73	14.7	4.79	14.7	4.85	14.6	4.98			
	-7.0	-7.6	15.3	4.55	15.2	4.68	15.2	4.80	15.2	4.86	15.2	4.92	15.1	5.04			
	-5.0	-5.6	15.9	4.65	15.9	4.77	15.9	4.88	15.9	4.94	15.8	5.00	15.7	5.05			
	-3.0	-3.7	16.6	4.74	16.5	4.85	16.5	4.96	16.5	5.02	16.5	5.07	16.4	5.11			
	0.0	-0.7	17.6	4.86	17.5	4.96	17.5	5.07	17.4	5.09	17.4	5.14	17.3	5.18			
	3.0	2.2	18.5	4.96	18.5	5.06	18.0	4.95	17.4	4.76	16.8	4.57	15.7	4.20			
	5.0	4.1	19.2	5.03	19.1	5.12	18.0	4.75	17.4	4.57	16.8	4.39	15.7	4.04			
7.0	6.0	19.8	5.09	19.2	4.93	18.0	4.57	17.4	4.40	16.8	4.22	15.7	3.89				
9.0	7.9	20.3	5.09	19.2	4.74	18.0	4.40	17.4	4.23	16.8	4.07	15.7	3.75				
11.0	9.8	20.3	4.90	19.2	4.57	18.0	4.24	17.4	4.08	16.8	3.93	15.7	3.62				
13.0	11.8	20.3	4.72	19.2	4.40	18.0	4.09	17.4	3.94	16.8	3.79	15.7	3.49				
15.0	13.7	20.3	4.56	19.2	4.25	18.0	3.96	17.4	3.81	16.8	3.66	15.7	3.38				
90% 16.20 kW (135.0)	-19.8	-20.0	11.1	3.99	11.0	4.15	11.0	4.30	11.0	4.37	11.0	4.45	10.96	4.60			
	-18.8	-19.0	11.4	4.08	11.4	4.22	11.4	4.37	11.3	4.45	11.3	4.52	11.30	4.67			
	-16.7	-17.0	12.1	4.23	12.1	4.37	12.0	4.51	12.0	4.58	12.0	4.65	11.97	4.79			
	-14.7	-15.0	12.7	4.37	12.7	4.50	12.7	4.63	12.7	4.70	12.7	4.76	12.63	4.89			
	-12.6	-13.0	13.4	4.49	13.4	4.61	13.4	4.74	13.3	4.80	13.3	4.86	13.30	4.99			
	-10.5	-11.0	14.1	4.60	14.1	4.72	14.0	4.84	14.0	4.90	14.0	4.96	13.97	5.08			
	-9.5	-10.0	14.4	4.65	14.4	4.77	14.4	4.88	14.3	4.94	14.3	5.00	14.12	5.01			
	-8.5	-9.1	14.7	4.70	14.7	4.81	14.7	4.92	14.6	4.98	14.6	5.04	14.12	4.89			
	-7.0	-7.6	15.2	4.77	15.2	4.88	15.2	4.99	15.1	5.04	15.1	5.10	14.12	4.69			
	-5.0	-5.6	15.9	4.86	15.9	4.96	15.8	5.07	15.7	5.05	15.2	4.85	14.12	4.45			
	-3.0	-3.7	16.5	4.93	16.5	5.03	16.2	5.01	15.7	4.81	15.2	4.62	14.12	4.25			
	0.0	-0.7	17.5	5.04	17.2	5.02	16.2	4.66	15.7	4.48	15.2	4.30	14.12	3.96			
	3.0	2.2	18.3	5.05	17.2	4.70	16.2	4.37	15.7	4.20	15.2	4.04	14.12	3.72			
	5.0	4.1	18.3	4.84	17.2	4.51	16.2	4.19	15.7	4.04	15.2	3.88	14.12	3.58			
	7.0	6.0	18.3	4.66	17.2	4.34	16.2	4.04	15.7	3.89	15.2	3.74	14.12	3.45			
9.0	7.9	18.3	4.48	17.2	4.18	16.2	3.89	15.7	3.75	15.2	3.61	14.12	3.33				
11.0	9.8	18.3	4.32	17.2	4.03	16.2	3.75	15.7	3.62	15.2	3.48	14.12	3.22				
13.0	11.8	18.3	4.17	17.2	3.89	16.2	3.62	15.7	3.49	15.2	3.36	14.12	3.11				
15.0	13.7	18.3	4.03	17.2	3.76	16.2	3.51	15.7	3.38	15.2	3.26	14.12	3.01				
80% 14.40 kW (120.0)	-19.8	-20.0	11.0	4.29	11.0	4.43	11.0	4.56	10.96	4.63	10.95	4.70	10.92	4.83			
	-18.8	-19.0	11.4	4.36	11.3	4.50	11.3	4.63	11.29	4.69	11.28	4.76	11.25	4.89			
	-16.7	-17.0	12.0	4.50	12.0	4.62	12.0	4.75	11.96	4.81	11.95	4.87	11.92	5.00			
	-14.7	-15.0	12.7	4.62	12.7	4.74	12.6	4.86	12.63	4.92	12.62	4.97	12.55	5.07			
	-12.6	-13.0	13.4	4.73	13.3	4.84	13.3	4.96	13.30	5.01	13.28	5.07	12.55	4.75			
	-10.5	-11.0	14.0	4.83	14.0	4.94	14.0	5.04	13.94	5.08	13.47	4.88	12.55	4.48			
	-9.5	-10.0	14.4	4.88	14.3	4.98	14.3	5.09	13.94	4.94	13.47	4.74	12.55	4.35			
	-8.5	-9.1	14.7	4.92	14.6	5.02	14.4	5.01	13.94	4.81	13.47	4.62	12.55	4.24			
	-7.0	-7.6	15.2	4.98	15.1	5.08	14.4	4.80	13.94	4.62	13.47	4.43	12.55	4.08			
	-5.0	-5.6	15.8	5.06	15.3	4.91	14.4	4.56	13.94	4.38	13.47	4.21	12.55	3.88			
	-3.0	-3.7	16.3	5.03	15.3	4.68	14.4	4.35	13.94	4.18	13.47	4.02	12.55	3.70			
	0.0	-0.7	16.3	4.68	15.3	4.36	14.4	4.05	13.94	3.90	13.47	3.75	12.55	3.46			
	3.0	2.2	16.3	4.38	15.3	4.09	14.4	3.80	13.94	3.67	13.47	3.53	12.55	3.26			
	5.0	4.1	16.3	4.21	15.3	3.93	14.4	3.66	13.94	3.53	13.47	3.40	12.55	3.14			
	7.0	6.0	16.3	4.05	15.3	3.78	14.4	3.53	13.94	3.40	13.47	3.27	12.55	3.03			
9.0	7.9	16.3	3.90	15.3	3.65	14.4	3.40	13.94	3.28	13.47	3.16	12.55	2.92				
11.0	9.8	16.3	3.77	15.3	3.53	14.4	3.29	13.94	3.17	13.47	3.06	12.55	2.83				
13.0	11.8	16.3	3.64	15.3	3.40	14.4	3.18	13.94	3.06	13.47	2.95	12.55	2.74				
15.0	13.7	16.3	3.52	15.3	3.30	14.4	3.08	13.94	2.97	13.47	2.86	12.55	2.65				

4TW32002-3

7 Capacity tables

7 - 3 Capacity Correction Factor

ERQ-AV1

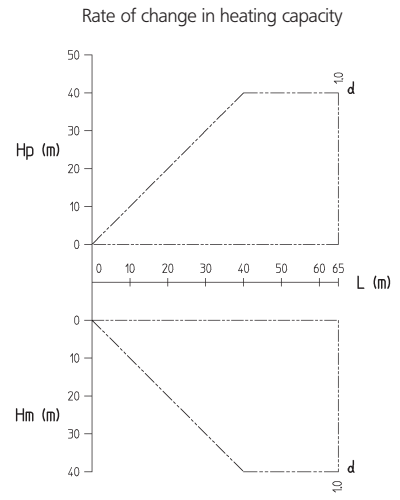
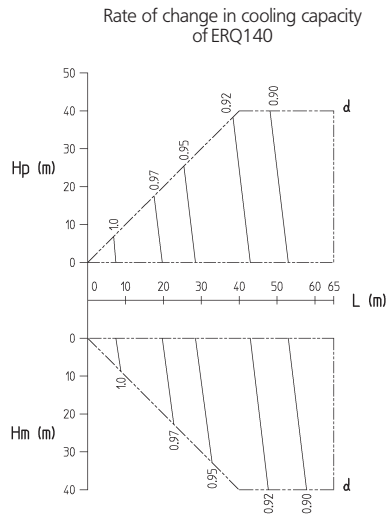
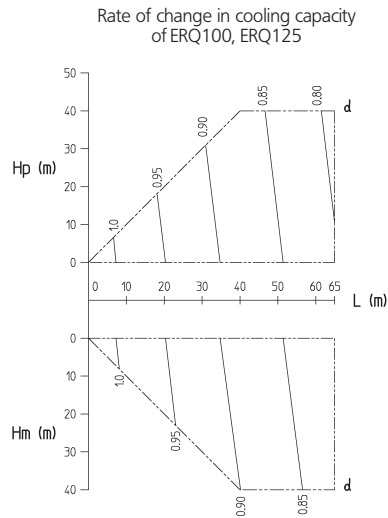

Notes:

- 1 These figures illustrate the rate of change in capacity of the system at maximum load under standard conditions. Under partial load conditions there is only a minor deviation from the rate of change in capacity shown in the figures above.
- 2 Method of calculating cooling capacity (max. capacity)
Cooling capacity = Cooling capacity obtained from the cooling capacity characteristics table X Capacity correction factor
- 3 Method of calculating heating capacity (max. capacity)
Heating capacity = Heating capacity obtained from the heating capacity characteristics table X Capacity correction factor

Explanation of symbols:

- Hp: Level difference (m) between indoor and outdoor unit when indoor unit is installed below the outdoor unit.
- Hm: Level difference (m) between indoor and outdoor unit when indoor unit is installed above the outdoor unit.
- L: Equivalent piping length (m)
- d: Capacity correction factor

Diameter of pipes:

Model	Gas	Liquid
ERQ100	φ 15.9	φ 9.5
ERQ125	φ 15.9	φ 9.5
ERQ140	φ 19.1	φ 9.5

3TW32002-1

8 Dimensional drawings

8 - 1 Dimensional Drawings

8

ERQ-AV1

4 holes for anchor bolts
M12

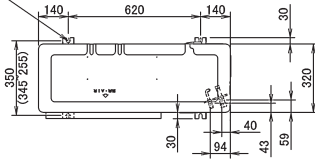

1	Gas pipe connection -A
2	Liquid pipe connection -Ø9.5- flare
3	(2X) Service port (in the unit)
4	Electronic connection and grounding terminal -M5- (in the switch box)
5	Refrigerant piping intake
6	Power supply wiring intake (knockout hole -Ø34-)
7	Control wiring intake (knockout hole -Ø27-)
8	Drain outlet

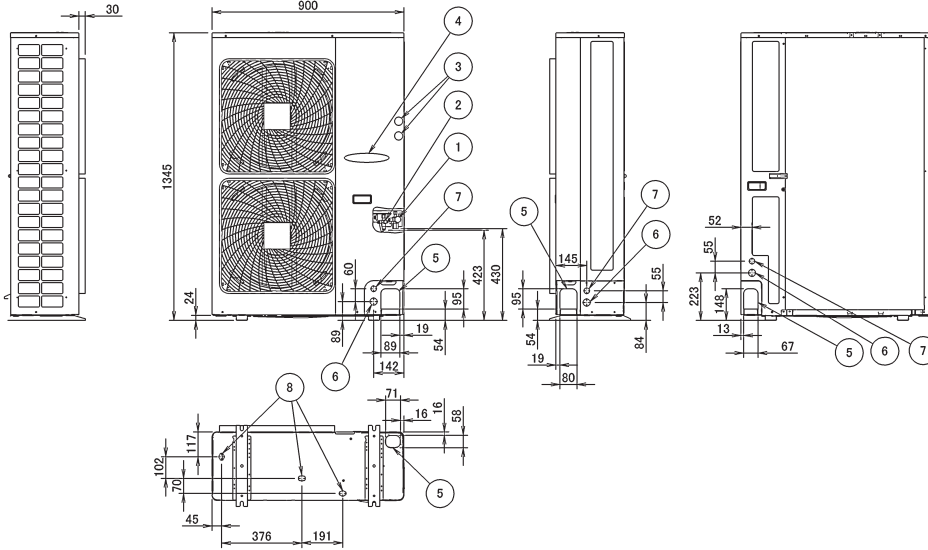

Model	A
ERQ100	Ø15.9- flared connection
ERQ125	Ø15.9- flared connection
ERQ140	Ø19.1- brazed connection

3TW32004-1A

9 Centre of gravity

9 - 1 Centre of Gravity

ERQ-AV1

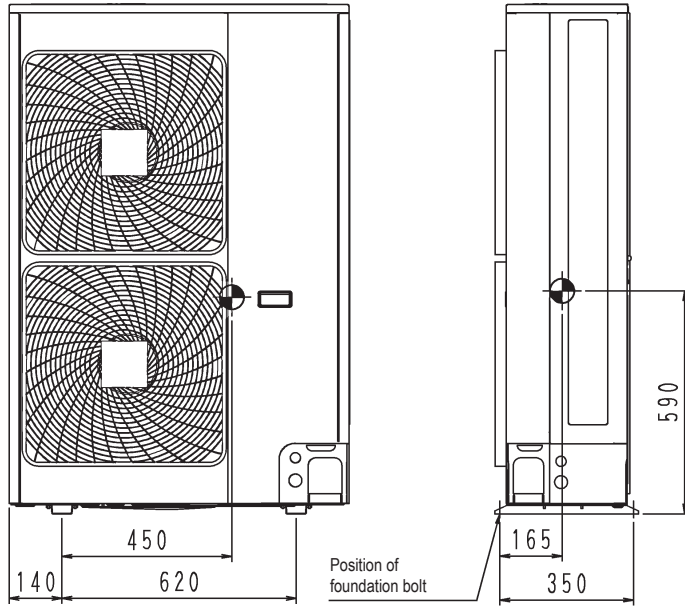

4D052604B

10 Piping diagrams

10 - 1 Piping Diagrams

10

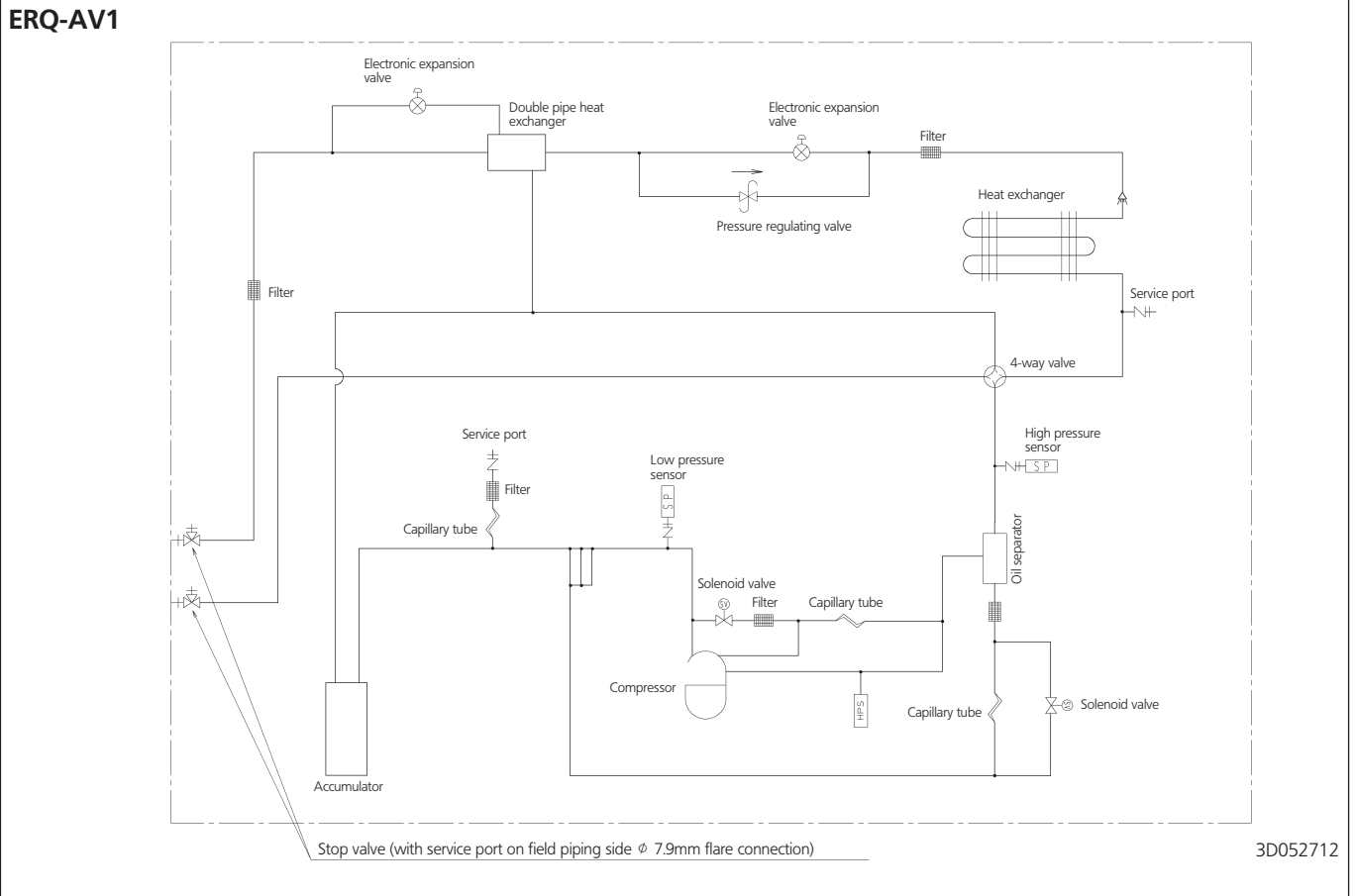

12 External connection diagrams

12 - 1 External Connection Diagrams

12

ERQ-AV1

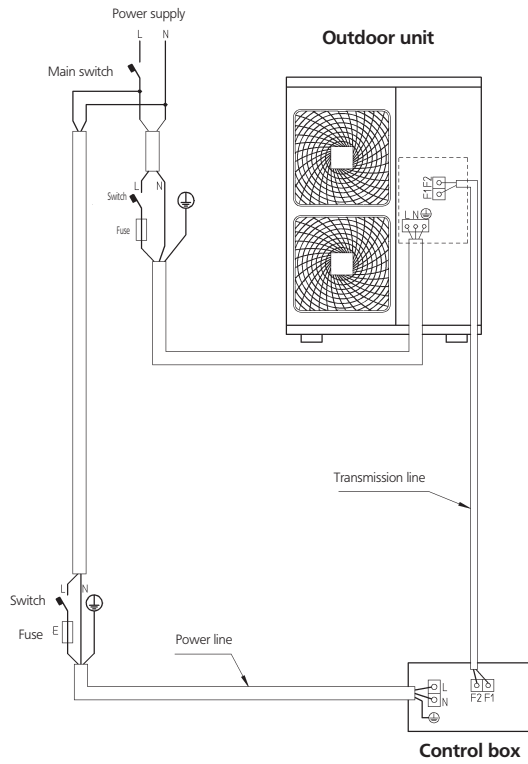

Notes:

- 1 All wiring, components and materials to be procured on the site must comply with the applicable local and national codes.
- 2 Use copper conductors only.
- 3 For more details, see wiring diagram.
- 4 Install a circuit breaker for safety.
- 5 All field wiring and components must be provided by a licensed electrician.
- 6 The unit shall be grounded in compliance with the applicable local and national codes.
- 7 Wiring shown are general points-of-connection guides only and are not intended for or to include all details for a specific installation.
- 8 Be sure to install the switch and the fuse to the power line of each equipment.
- 9 Install the main switch that can interrupt all power sources in an integrated manner because this system consists of the equipment utilizing the multiple power sources.
- 10 For detailed control box side connection, see control box manual and wiring diagram.

3TW27176-2

13 Sound data

13 - 1 Sound Power Spectrum

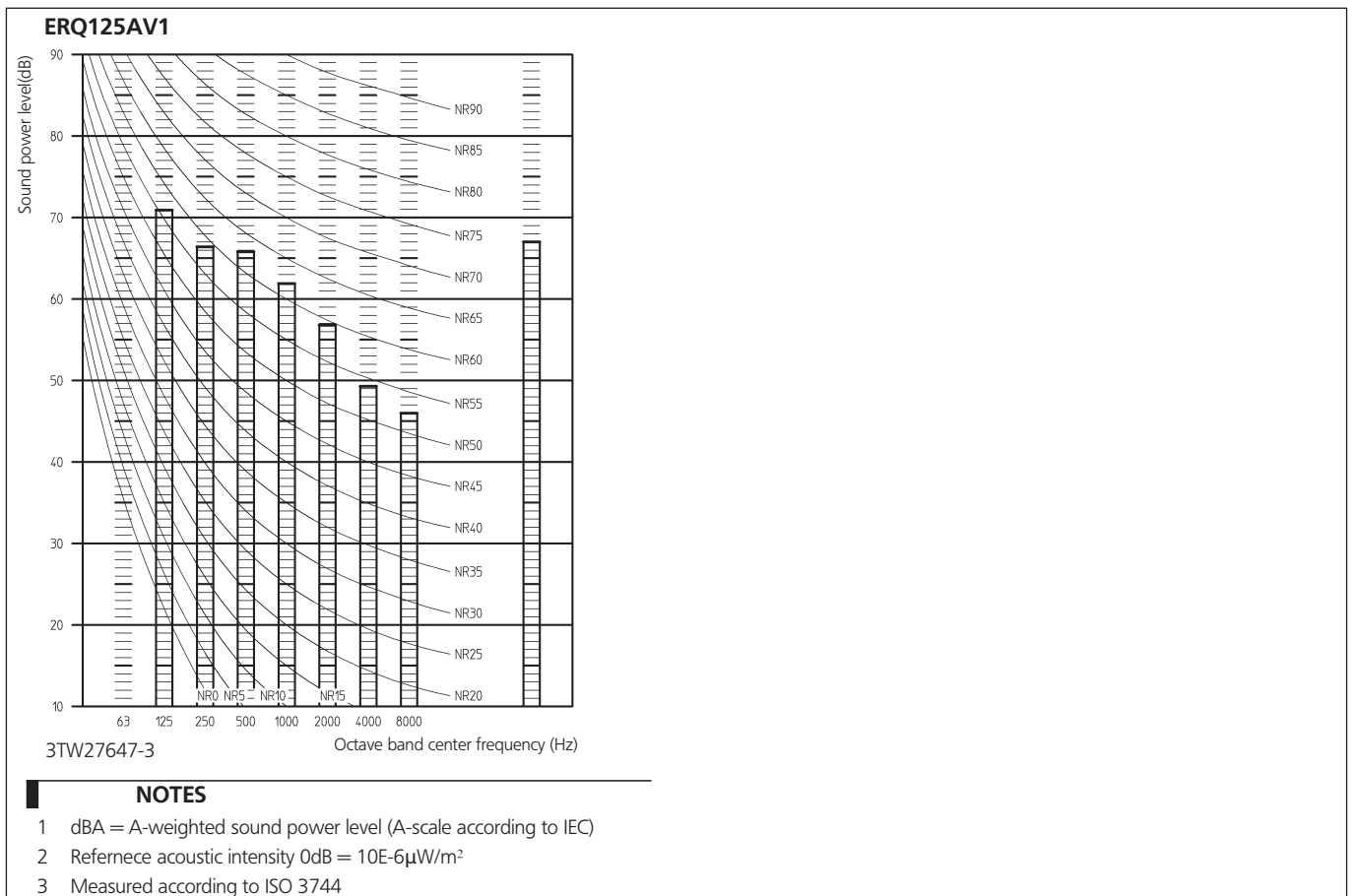
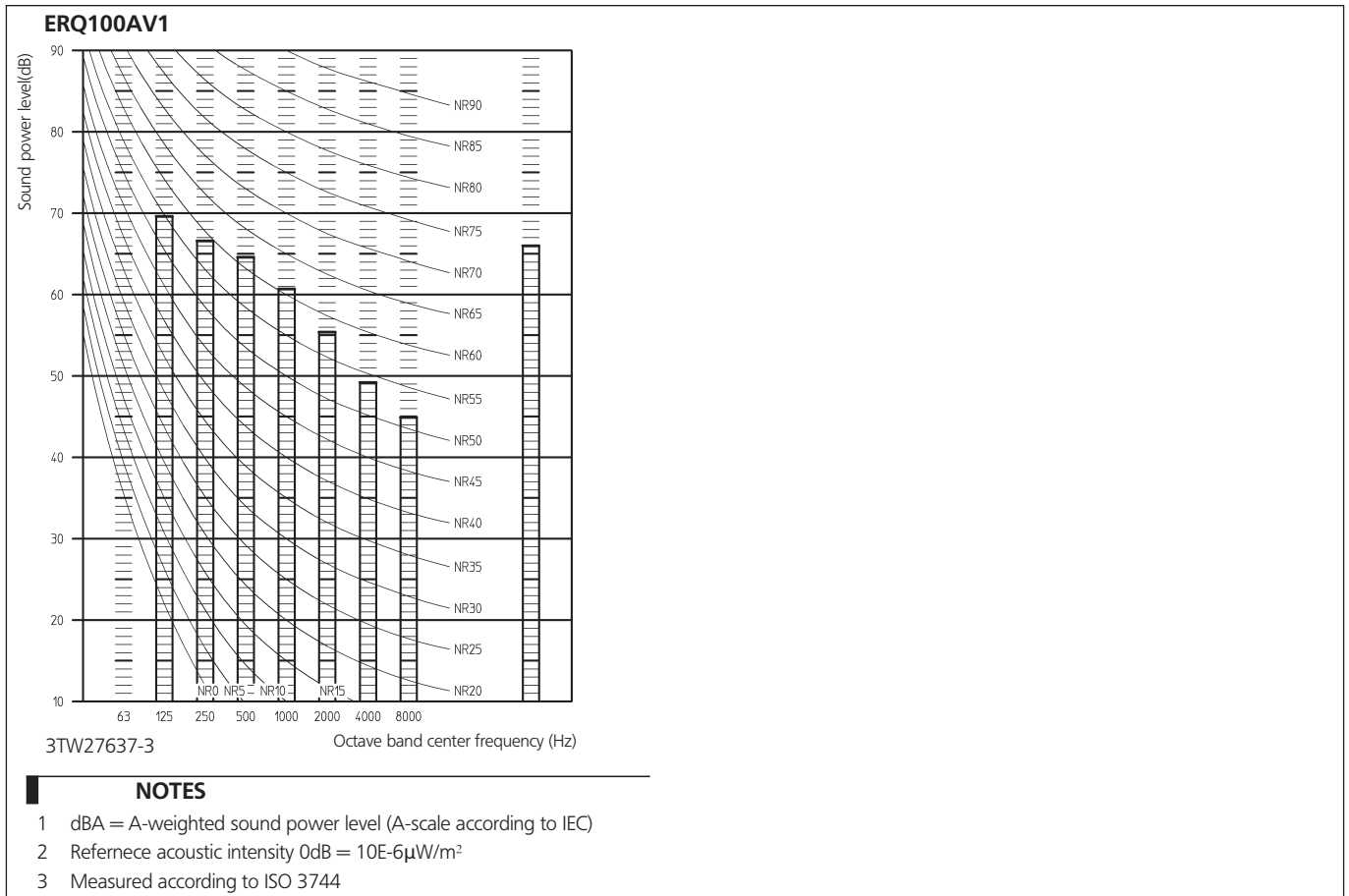

13 Sound data

13 - 1 Sound Power Spectrum

13

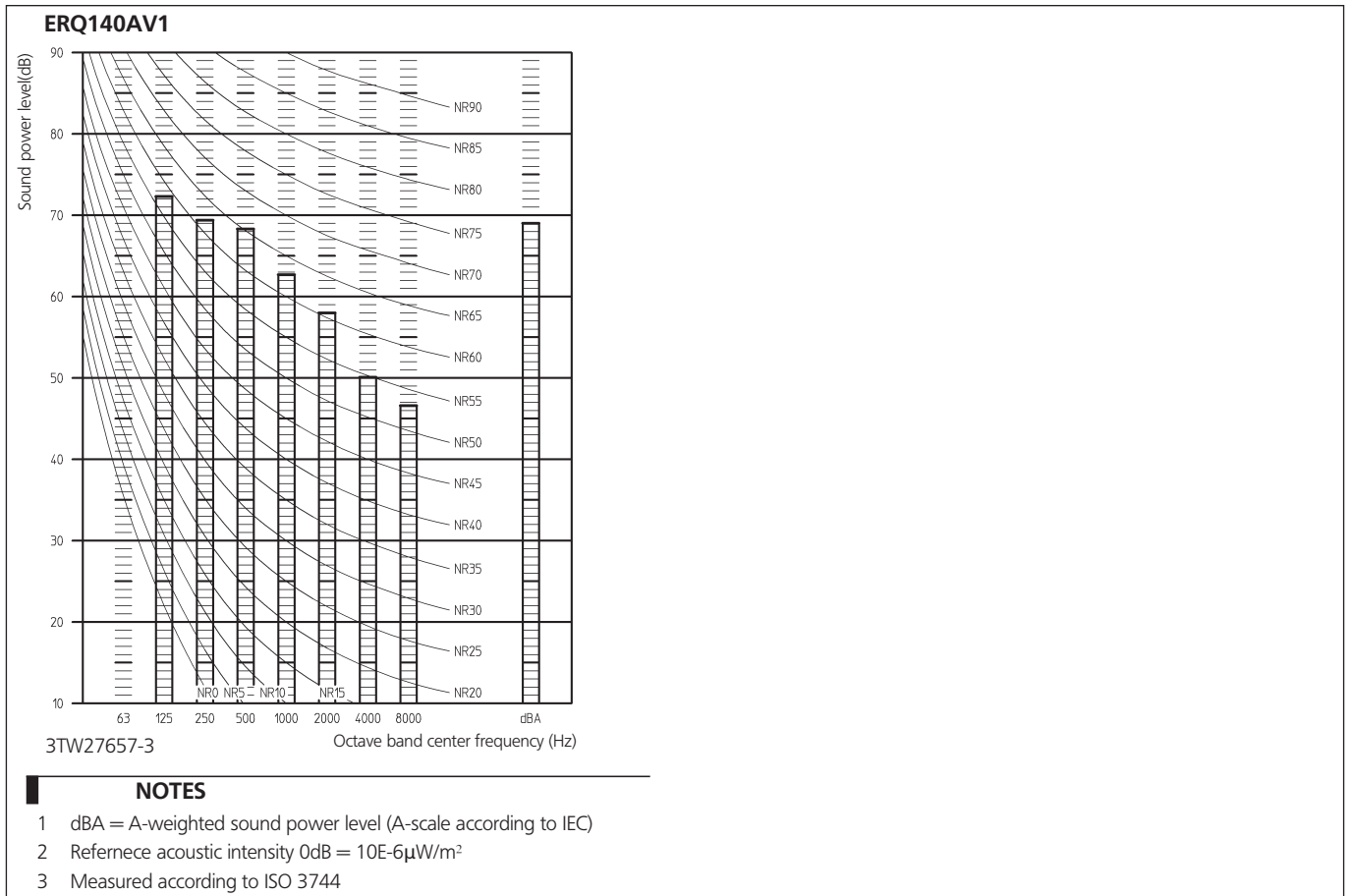

13 Sound data

13 - 2 Sound Pressure Spectrum - Cooling

ERQ140AV1

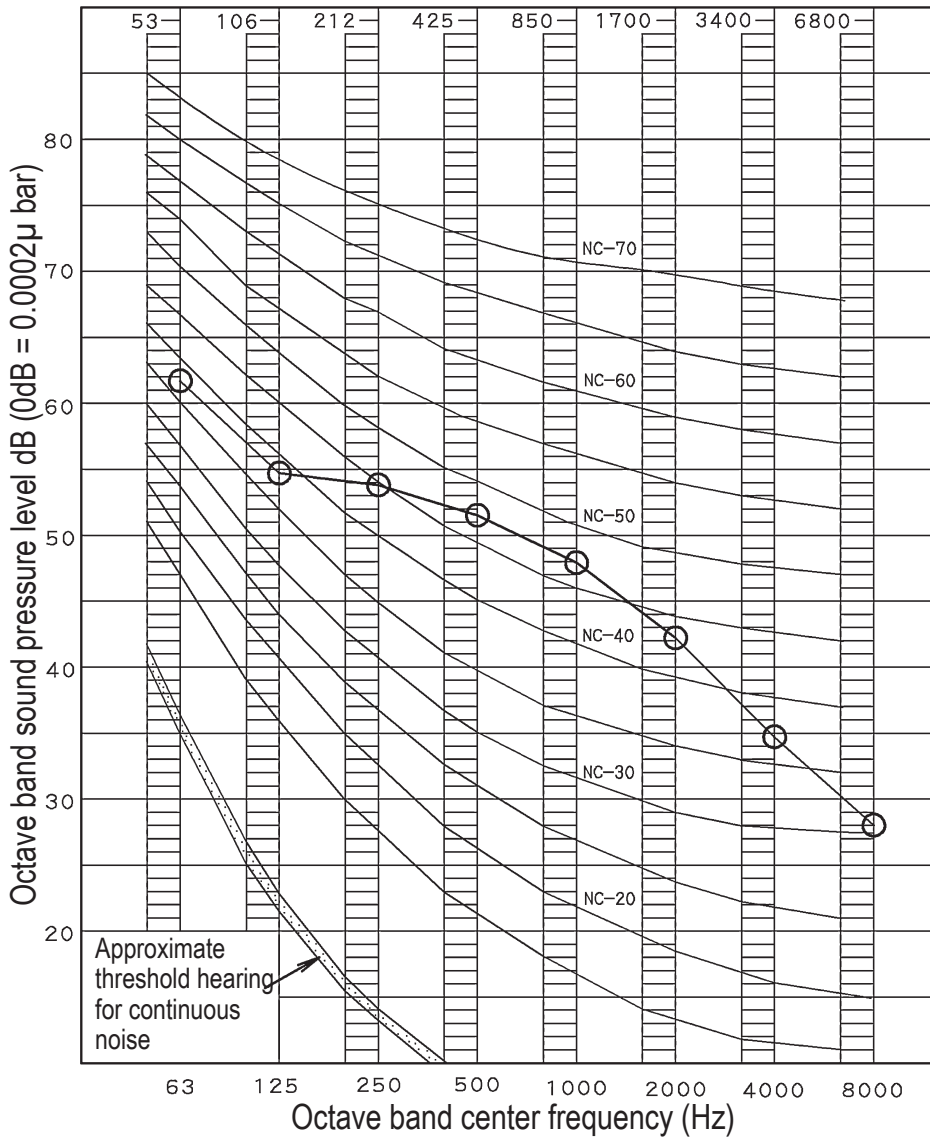

NOTES

1. Over All (dB):

Scale A	53.0
Scale C	64.5

(B,G,N is already rectified)

2. Measuring place

Anechoic chamber

3. Operating conditions

Power source: 220-240V 50Hz, 220V 60Hz

Cooling

Return air temperature: 27°C DB, 19°C WB

Outdoor temperature: 35°C DB, 24°C WB

5. The operating sound is measured in anechoic chamber, if it is measured under the actual installation conditions, it is normally over the set value due to environmental noise and sound reflection.

4. Location of microphone.

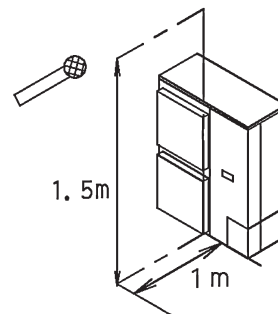

4D052716K

13 Sound data

13 - 2 Sound Pressure Spectrum - Cooling

13

ERQ125AV1

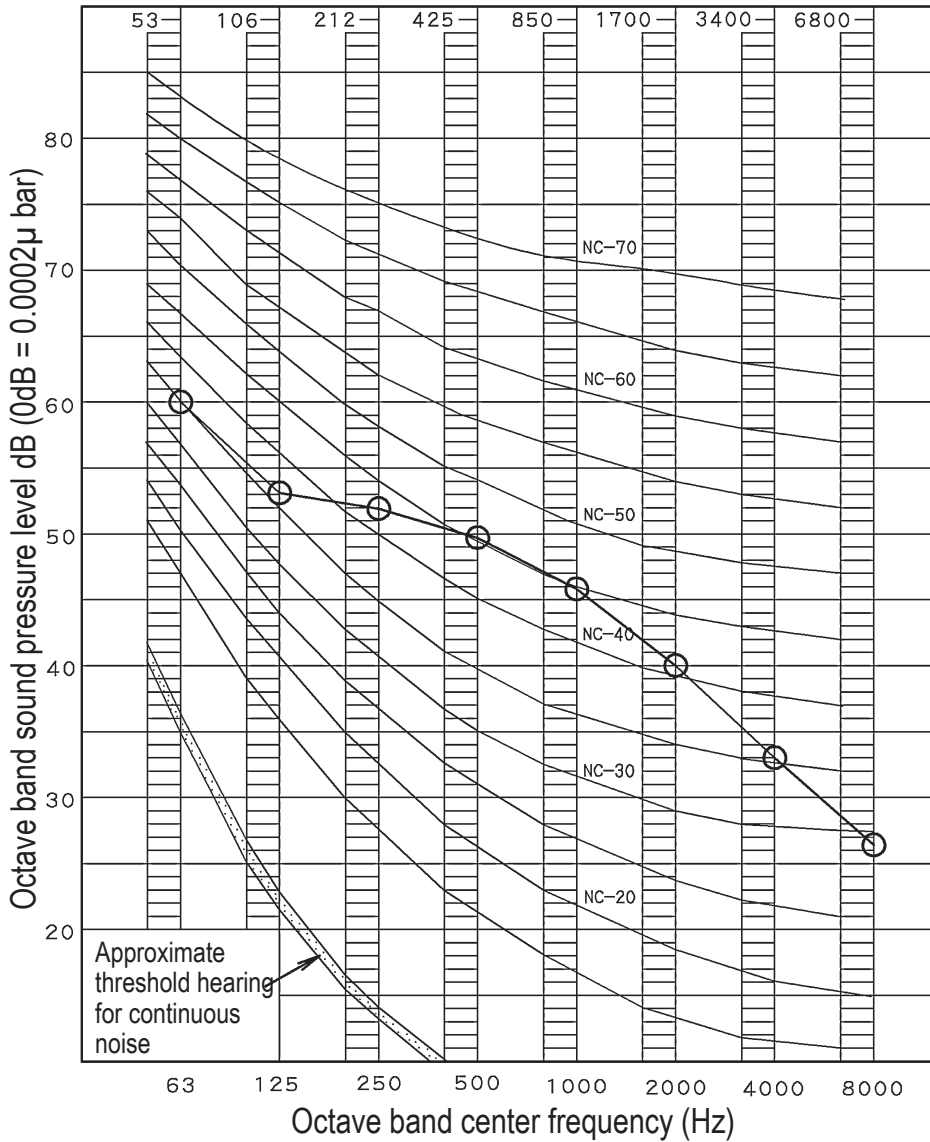

NOTES

1. Over All (dB):

Scale A	51.0
Scale C	63.5

(B,G,N is already rectified)

2. Measuring place

Anechoic chamber

3. Operating conditions

Power source: 220-240V 50Hz, 220V 60Hz

Cooling

Return air temperature: 27°C DB, 19°C WB

Outdoor temperature: 35°C DB, 24°C WB

5. The operating sound is measured in anechoic chamber, if it is measured under the actual installation conditions, it is normally over the set value due to environmental noise and sound reflection.

4. Location of microphone.

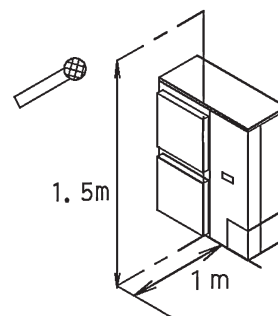

4D052714L

14 Installation

14 - 1 Installation Method

ERQ-AV1

Required installation space
The unit of the values is mm.

1. Where there is an obstacle on the suction side:

(a) No obstacle above

(1) Stand-alone installation

- Obstacle on the suction side only

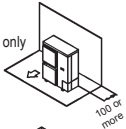

- Obstacle on both sides

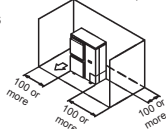

(2) Series installation (2 or more)

- Obstacle on both sides

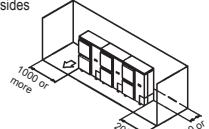

(b) Obstacle above, too

(1) Stand-alone installation

- Obstacle on the suction side, too

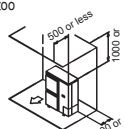

- Obstacle on the suction side and both sides

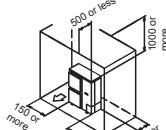

(2) Series installation (2 or more)

- Obstacle on the suction side and both sides



2. Where there is an obstacle on the discharge side:

(a) No obstacle above

(1) Stand-alone installation

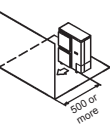

(2) Series installation (2 or more)

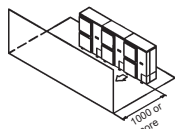

(b) Obstacle above, too

(1) Stand-alone installation

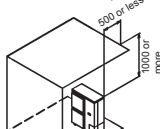

(2) Series installation (2 or more)

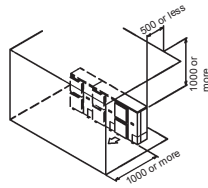

3. Where there are obstacles on both suction and discharge sides:

Pattern 1

Where the obstacles on the discharge side is higher than the unit: (There is no height limit for obstructions on the intake side.)

(a) No obstacle above

(1) Stand-alone installation

$$L > H$$

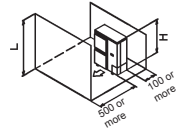

(2) Series installation (2 or more)

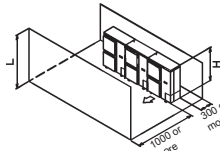

(b) Obstacle above, too

(1) Stand-alone installation

The relation between H, A and L are as follows:

	L	A
$L \leq H$	$0 < L \leq 1/2H$	750
	$1/2H < L \leq H$	1000
$H < L$	Set the stand as: $L \leq H$	

Close the bottom of the installation frame to prevent the discharged air from being bypassed.

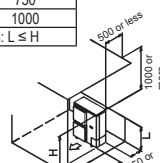

(2) Series installation (2 or more)

The relation between H, A and L are as follows:

	L	A
$L \leq H$	$0 < L \leq 1/2H$	1000
	$1/2H < L \leq H$	1250
$H < L$	Set the stand as: $L \leq H$	

Close the bottom of the installation frame to prevent the discharged air from being bypassed.

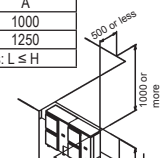

Only two units can be installed for this series.

Pattern 2

Where the obstacles on the discharge side is lower than the unit: (There is no height limit for obstructions on the intake side.)

(a) No obstacle above

(1) Stand-alone installation

$$L \leq H$$

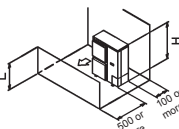

(2) Series installation (2 or more)

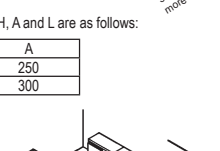

The relation between H, A and L are as follows:

	L	A
$L \leq H$	$0 < L \leq 1/2H$	250
	$1/2H < L \leq H$	300

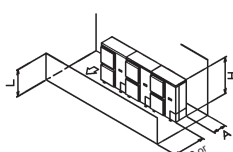

(b) Obstacle above, too

(1) Stand-alone installation

The relation between H, A and L are as follows:

	L	A
$L \leq H$	$0 < L \leq 1/2H$	100
	$1/2H < L \leq H$	200
$H < L$	Set the stand as: $L \leq H$	

Close the bottom of the installation frame to prevent the discharged air from being bypassed.

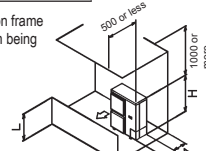

(2) Series installation

The relation between H, A and L are as follows:

	L	A
$L \leq H$	$0 < L \leq 1/2H$	250
	$1/2H < L \leq H$	300
$H < L$	Set the stand as: $L \leq H$	

Close the bottom of the installation frame to prevent the discharged air from being bypassed.

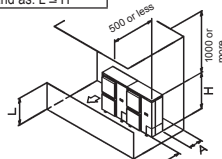

Only two units can be installed for this series.

4. Double-decker installation

(a) Obstacle on the discharge side

Close the gap A (the gap between the upper and lower outdoor units) to prevent the discharged air from being bypassed.

Do not stack more than two unit.

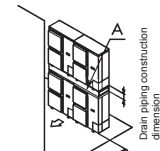

(b) Obstacle on the suction side

Close the gap A (the gap between the upper and lower outdoor units) to prevent the discharged air from being bypassed.

Do not stack more than two unit.

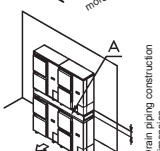

5. Multiple rows of series installation (on the rooftop, etc.)

(a) One row of stand-alone installation

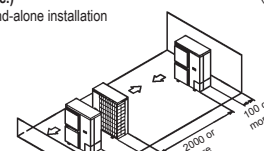

(b) Rows of series installation (2 or more)

The relation between H, A and L are as follows:

	L	A
$L \leq H$	$0 < L \leq 1/2H$	250
	$1/2H < L \leq H$	300
$H < L$	Cannot be installed	

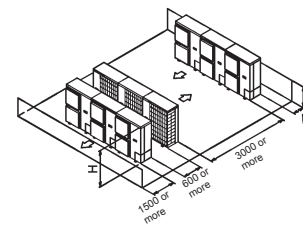

15 Operation range

15 - 1 Operation Range

15

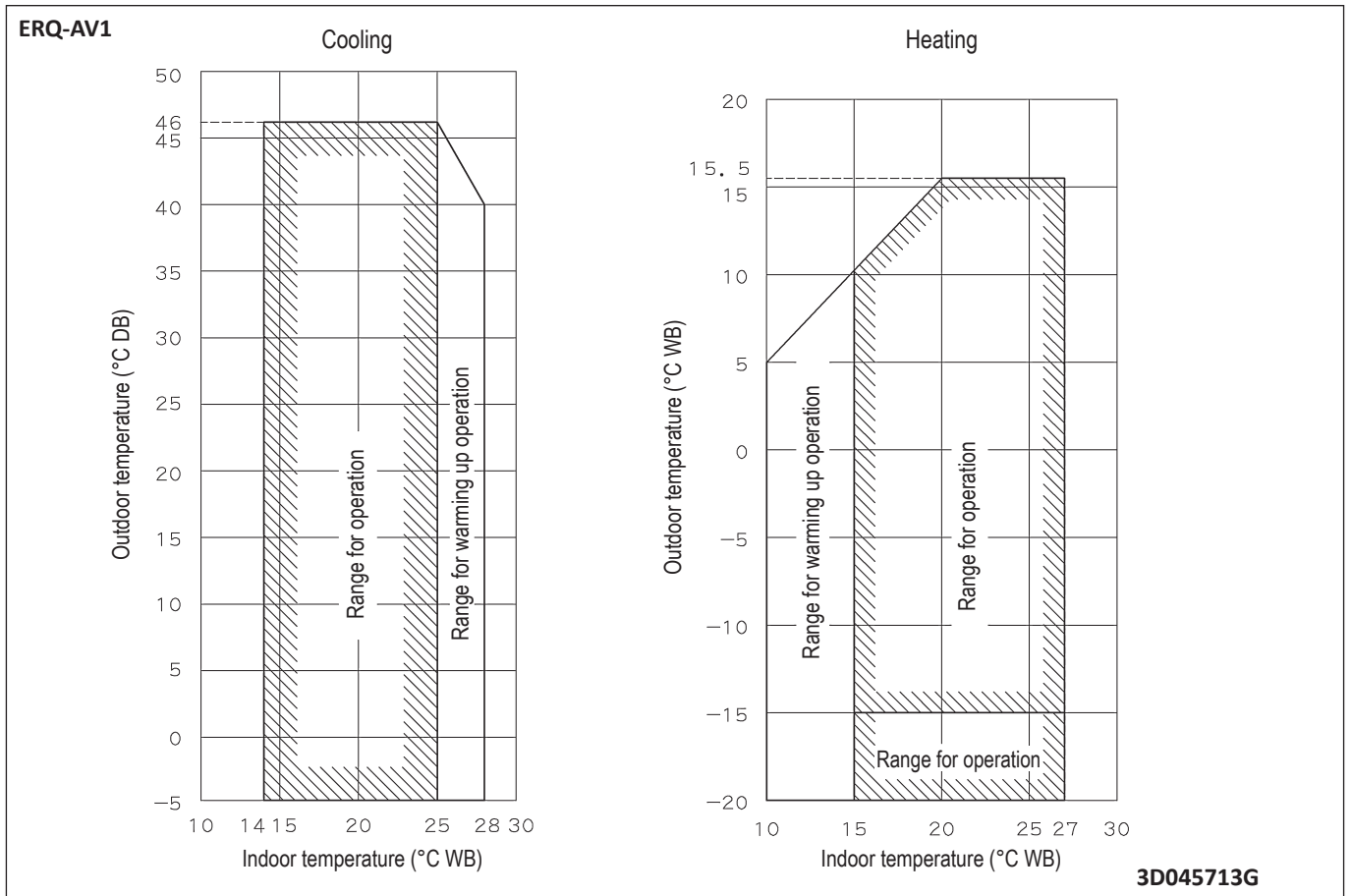

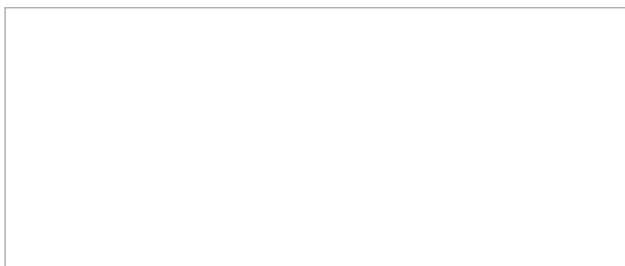

EEDEN20

08/2020



The present leaflet is drawn up by way of information only and does not constitute an offer binding upon Daikin Europe N.V. Daikin Europe N.V. has compiled the content of this leaflet to the best of its knowledge. No express or implied warranty is given for the completeness, accuracy, reliability or fitness for particular purpose of its content and the products and services presented therein. Specifications are subject to change without prior notice. Daikin Europe N.V. explicitly rejects any liability for any direct or indirect damage, in the broadest sense, arising from or related to the use and/or interpretation of this leaflet. All content is copyrighted by Daikin Europe N.V.